



专业 | 专注 | 诚信
Professional | Focus | Integrity

以专业引领科技，以科技成就专业
Professionalism navigates science & technology, science & technology conceives speciality



江苏大明波纹管有限公司
JIANGSU DAMING CORRUGATED PIPE CO.,LTD

INDEX

- I. About DAMING**
- II. Factory Photos**
- III. Certification**
- IV. Technical Equipment**
- V. Flexible Metal Hose Production**
 - Spiral Corrugated Flex Hose
 - Annular Corrugated Flex Hose
 - Interlock Pipe
 - Metal Wire Braid
 - Shock Absorbing Metal Hose
 - Pump Connection Hose
 - PTFE Flexible Metal Hose
 - Fire Sprinkler Hose
- VI. Expansion Joints Production**
 - Universal Expansion Joint
 - Rotary Compensator
 - PTFE Expansion Joint
 - Large Rod Expansion Joint
 - Rubber Expansion Joint
- VII. Products Show**

COMPANY INTRODUCTION



➤ ABOUT DAMING

Since 1995, Jiangsu Daming Corrugated Pipe Co.,Ltd (formerly Jiangyan Daming Supporting Machinery Co.,Ltd) has grown up to be the leading professional manufacture of corrugated pipe, expansion joint in China. Our company is specialized in the design, manufacture, market and service of integrated solutions of flexible pipe connection. The headquarter of Daming Corrugated Pipe is located in Jiangyan City,Jiangsu Province,China, which is about 3 hours from Shanghai. We have over 100 employees,including 20 skilled engineers and high trained technicians. It has an area of nearly 12,000 square meters produce center and current annual production is valued at more than USD4,000,000.

Currently, Daming products mainly include corrugated pipe,metal hose ,bellows expansion joint , non-metallic expansion joint,non-metallic high temperture fabric compensator, stainless steel mesh,polyfluoroethylene pipe, diesel engine intake pipe, exhaust pipe ect. The products are widely applied in the fields of petroleum,chemical industry,aerospace,smelt,electricity, building, mechanical,iron and steel,paper making, fabric, gas,medicine,food and vessels ect. The sales market and customers are across the world and products have been exported to Southeast Asia,Middle East,Europe and America ect where being highly relied on and complimented by customers in domestic and oversea.

Company produce corrugated pipe in accordance with the GB/T14525-2010 standard production, has the advantages of light weight,small volume,corrosion resistant,high temperture,high pressure, good flexibility, strong seal,and long life. We supply expansion joint according to American standard of EJMA ,ASME and GB/12777-2008,it can bear high pressure, various displacement , have large amount of compensation and function of noise reduction ,damping. The products in our company are ISO9001-2008 quality system certified.

Based on the pragmatic attitude of “Professional, Focus, Integrity”, we will consistently strive for excellent products, increase product content of science and technology, and supply customers with best products and services.

➤ FACTORY PHOTO



F 厂房厂貌
actory scene





➤ CERTIFICATION

公司证书

The company certificate

Higher quality Better services

品 / 质 / 更 / 优 服 / 务 / 更 / 好



➤ TECHNICAL EQUIPMENT



科技创新 质量兴业

Science and technology innovation Quality promotes education

technical equipment >>>

技术设备



一流设备 **国内领先**

赢在起跑线上……



technical equipment >>>

技术设备

严把工艺流程中每一道工序，是我们至上品质的保证。

The strict control on every link in the technological flow is the guarantee of our superior quality.





科技创新 质量兴业

Science and technology innovation Quality promotes education

SYSTEMATIC TESTING EQUIPMENT FINE QUALITY IS GUARANTEED 系统的检测设备 优良的品质保证



- 完善的系统检测设备。
- 以专业严谨的态度、自主进取的研发精神。
- 保证我们一流的产品品质。
- The complete systematic testing equipment guarantees Our first-class
- products quality with the attitude of rigorous speciality, and the spirit of aggressive
- research and self probing.

➤ FLEXIBLE METAL HOSE PRODUCTION

Spiral Corrugated Flex Hose



$$6 \leq DN \leq 63.5$$

Description

The corrugated pipe is made of stainless steel strip by the unit, automatic cutting, rolling, TIG welding, corrugated forming, all the processes are finished in one production line.

L Type spiral corrugated flexible body has a continuous spiral waveform, not need butt welding. Used for static and small amount of exercise occasions.

Material: 321, 304 ☆, 316, 316 L SS Stainless Steel

Technique Parameter

Nominal Diameter		Internal Diameter I. D	Outer Diameter O. D (mm)		Minimum Bend Radius R. (mm)		Nominal Pressure PN (MPa)		
DN			Bellows	One layer braid	Static	Dynamic	1 Layer Braid	2 Layer Braids	3 Layer Braids
(mm)	(in)	(mm)							
6	1/4	6	10.4	11.6	50	110	23	32	/
8	5/16	8	11.1	13.1	65	145	23	32	/
10	3/8	10.9	15	17	80	180	23	32	/
12	1/2	12	18.4	20.4	95	215	23	32	/
15	5/8	15.5	21.5	23.5	120	270	21	25	/
20	3/4	20	25	27	160	360	16	25	32
25	1	25	32.5	34.5	175	400	10	15	25
32	1 1/4	31	41	43	225	510	6.3	10	15
40	1 1/2	40	50	52.5	280	640	4.0	6.3	10
50	2	50	62	64.5	350	800	2.5	4.0	6.3
65	2 1/2	62	75	77.5	390	845	2.5	4.0	6.3

☆ If there is no special statement, the bellows is made of 304SS Stainless steel

☆ If not make out working pressure, according to 0.6MPa design

Annular Corrugated Flex Hose



$$12 \leq DN \leq 800$$

Description

The corrugated pipe is made of stainless steel strip by the unit, automatic cutting, rolling, TIG welding, corrugated forming. H Type corrugated flexible body with a continuous circleline waveform, good softness. Difficult to produce torsional stress, applied in sport occasions and long life requirements of the occasion.

Material: 321, 304, 316, 316 L SS Stainless Steel

Technique Parameter

Nominal Diameter DN		Internal Diameter I. D	Outer Diameter O. D (mm)		Minimum Bend Radius R. (mm)		Nominal pressure PN (MPa)		
(mm)	(in)	(mm)	Bellows	One layer braid	Static	Dynamic	1 Layer Braid	2 Laye Braids	3 Laye Braids
12	1/2	12	18	21	40	130	10	12	25
15	5/8	15	21.5	24.5	70	190	10	12	25
18	11/16	18	25	28	90	205	8	12	25
20	3/4	20	28	33	175	400	7.5	12	25
25	1	24.4	32.5	35	225	510	6.3	10	15
32	1 1/4	32	41	45	280	640	4.0	6.3	10
40	1 1/2	39.6	51	55	350	800	2.5	4.0	6.3
50	2	49.7	62	66	390	845	2.5	4.0	6.3
65	2 1/2	64.8	78.5	82	480	1000	2.5	4.0	6.3
80	3	74.7	98	102	600	1200	2.5	4.0	5.0
100	4	96.5	120	125	750	1500	2.5	4.0	5.0
125	5	124.7	152	157	900	1800	2.0	2.5	4.0
150	6	149.4	182	187	1000	2000	1.6	2.5	4.0
200	8	199.4	236	243	1250	2500	1.6	2.5	4.0
250	10	248	292	297	1250	2500	1.6	2.5	, 4.0

300	12	298	348	353	1500	3000	1.6	2.0	2.5
350	14	347.6	398	403	1750	3500	1.0	2.0	2.5
400	16	398	448	453	2000	4000	1.0	1.6	2.5
450	18	448	498	503	2250	4500	1.0	1.6	2.5
500	20	498	548	553	2500	5000	1.0	1.6	2.5
600	24	598	648	653	3000	6000	0.6	1.0	1.6
700	28	698	748	753	3500	7000	0.6	1.0	1.6
800	32	798	848	853	4000	8000	0.6	1.0	1.6

☆ If there is no special statement, the bellows is made of 304SS Stainles steel

☆ If not make out working pressure ,according to 0.6MPa design

Interlock Pipe



$$20 \leq DN \leq 385$$

Description

Pipe is made of stainless steel which entwined, all the processes in one production line. C Type Pipe is softness, small reaction force when bending, well seismic performance, easy install. Used in the composite flexible body to reduce flow resistance, it can be the outside cover layer to prevent the hose extreme bending when work. Or used for the exhaust system as the exhaust pipe.

Material: 201, 304, 321 SS Stainles Steel

Technique Parameter

Nominal Diameter DN (mm)	Internal Diameter I. D (mm)	Outer Diameter O. D (mm)	Minimum Bend Radius R (mm)	
			Static	Dynamic

20	20.0	23.0	110	220
23	23.0	25.5	120	240
25	25.0	28.0	130	260
28	28.0	30.5	140	280
30	30.0	33.0	170	340
32	32.0	35.0	180	360
35	35.0	38.0	190	380
38	38.0	41.0	190	380
40	40.0	43.0	210	420
42	42.0	45.1	210	420
45	45.0	48.0	230	460
50	50.0	53.0	250	500
55	55.0	58.0	270	540
60	60.0	64.0	320	640
65	65.30	69.0	340	680
70	70.0	74.0	360	720
75	75.0	79.0	380	760
80	80.0	84.0	400	800
84	84.0	88.0	460	920
90	90.0	94.0	440	880
100	100.0	104.0	480	960
110	110.0	115.0	520	1040
120	120.0	125.0	560	1120
125	125.0	130.0	580	1160
130	130.0	137.0	640	1280
140	140.0	147.0	680	1360
150	150.0	157.0	720	1440
160	160.0	167.0	760	1520
175	175.0	182.0	820	1640
180	180.0	187.0	860	1720
185	185.0	192.0	900	1800
200	200.0	208.0	970	1940
235	235.0	241.0	1080	2160
285	285.0	291.0	1200	2400
335	335.0	341.0	1320	2640
385	385.0	391.0	1430	2860

Metal Wire Braid

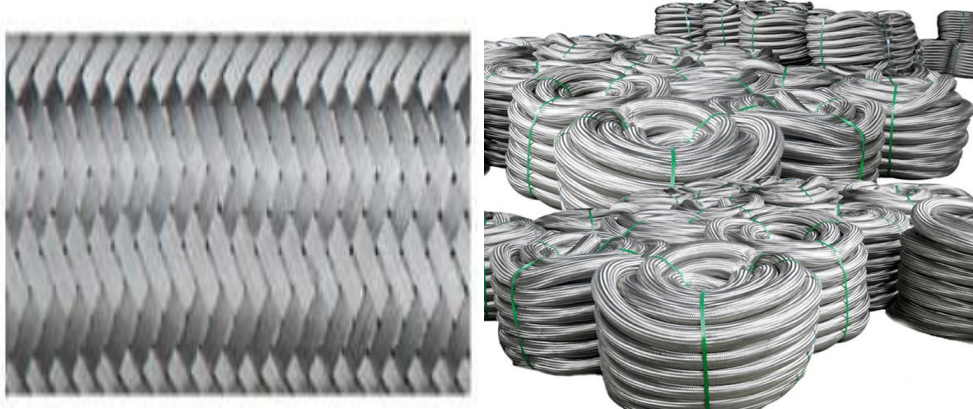

Description

Net body is composed of stainless steel hydrogen drawing which multi-ply braided, it's flexible and pressure high.

Material: 304 ☆, 321, 316, 316L Stainless Steel

Technique Parameter

Nominal Diameter DN (mm)	Internal Diameter I. D (mm)	Outer Diameter O. D (mm)	Ply n	Wire Diameter mm	Weight Kg/m
8	12.5	6	24	0.3	0.13
10	16	7	24	0.3	0.17
12	19.5	8	24	0.3	0.19
15	22.5	7	36	0.3	0.21
18	27	8	36	0.3	0.3
20	29.5	9	36	0.3	0.31
25	34.5	10	36	0.3	0.39
32	43	12	36	0.3	0.55
40	53	10	48	0.4	0.75
50	65	12	48	0.4	0.95
65	81	14	48	0.4	1.3
80	102	14	72	0.4	1.6
100	124	16	72	0.4	1.9
125	156	12	96	0.5	2.8
150	186	15	96	0.5	3.9
200	244	18	96	0.5	5.6
250	297	18	112	0.5	6.5
300	353	18	144	0.5	7.5
350	403	18	148	0.5	8.5
400	453	18	160	0.5	10.5

Shock Absorbing Metal Hose



Description

Installed in inlet and outlet tube system of the storage tank, mainly installed in the front of the tank valve, reduce earthquake damage of the tank and used to compensate for tank foundation subsidence, thermal expansion and contraction of the pipeline, installation deviation in the process of construction.

($40 \leq DN \leq 150$)

($200 \leq DN \leq 800$)

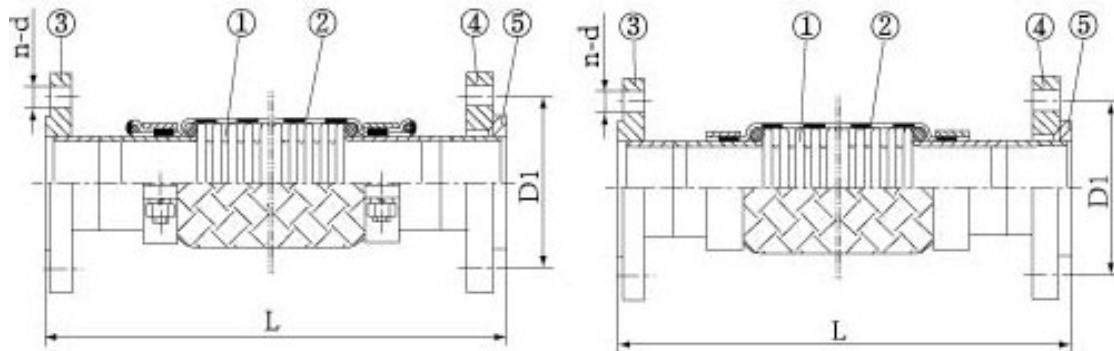

1. bellow 2. braid 3. welded flange 4. loose flange 5. sealing seat

The Product Structure Features

1. Use the material of steel net
2. $\varnothing 40 \sim \varnothing 150$ is mechanical clamping structure, $\varnothing 200 \sim \varnothing 700$ is welded structure
3. Flange connection in the two ends: one end of flat welding, one end of loose flange

Pump Connection Metal Hose



Description

Composition of pump, compressors, valves, instrumentation in the pipe system , often damage the key components such as instrument , affect the normal work , even cause piping resonance, damage piping and equipments;And vibration have series noise pollution. We develop the pump connection hose that can absorb piping system vibration and reduce noise. Widely used in steel factory water treatment working shop, petrochemical terminals, oil refinery, shipyards, high-rise buildings.

No connection tube structure

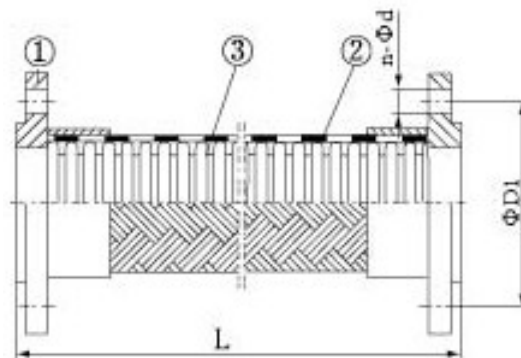

1. flange 2. braid 3. bellow

Connection tube structure

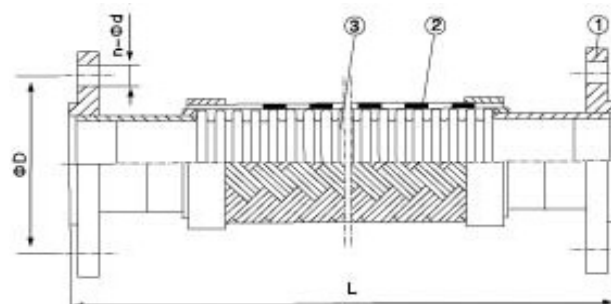

1. flange 2. braid 3. bellow

Accompany Metal Hose



Description

Accompanied hose is that pipe transmit medium normally , attached transmit heating medium, cooling or insulating. Accompanied hoses are generally transmit viscosity liquids , difficult flow medium which need heated in normal temperature; or the insulation medium which is liquid below zero degree and vaporize easily in normal temperature. Such as crude oil, asphalt, sulfur, liquid hydrogen, liquid oxygen and so on . The main material is stainless steel, less corrosion and leakage phenomenon. Have the function of compensate movement, vibration absorption, compensate install deviation.

Structure form have:

- a. Inner accompany flexible hose
- b. Jacket accompany flexible hose

a. Inner accompany flexible hose structure diagram

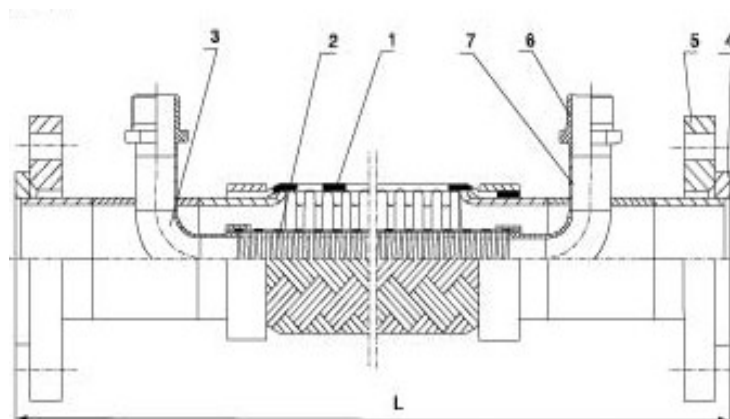

1. main body 2. accompany pipe 3. Elbow pipe 4. sealing seat 5. loose flange 6. joint 7. straight tube

b. Jacket accompany flexible hose structure diagram

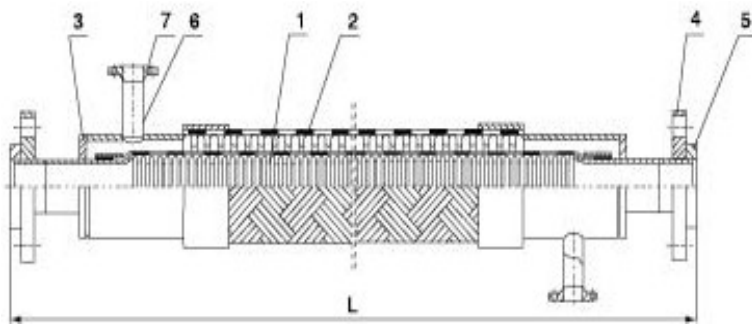

- 1.main body 2.accompany pipe 3.block plate 4.loose flange 5.sealing seat 6.straight tube
- 7.accompany pipe flange

PTFE Flexible Metal Hose



15≤DN≤200

Description

PTFE(F4), due to its excellent dielectric properties and chemical resistance, properties of water repellent, non-stick, non-conductive, low friction coefficient and non-aging, widely used in chemical, petroleum, textile, pharmaceutical, metallurgy, machinery, electronics, appliances, electricity, food and aviation.

Generally connected with flange, union connection fittings, threaded, quick connectors, as well as connect with the pipe directly, fixed by pipe strap or wire.

Technique Parameter

Nominal Diameter	Connector		PTFE Bellow Diameter		Wall thickness	Negative Pressure	Heat Distortion Temperature	Fatigue Life	Length
	DN (mm)	Diameter mm	Length mm	Outer mm					
15	15	30-50	17.0	10	1.5	90	< 150℃	≥100,000	mm
20	20	30-50	22.4	15	1.5	90	< 150℃	≥100,000	

25	25	30-50	27.6	20	1.5	90	< 150℃	≥100,000	200~ 20000MM
32	32	40-60	35.8	25	1.6	85	< 150℃	≥100,000	
40	40	40-60	40.8	30	2.0	80	< 150℃	≥100,000	
50	50	40-60	54.0	40	2.0	75	< 150℃	≥100,000	
57	57	50-70	60.2	45	2.0	70	< 150℃	≥100,000	
65	65	50-70	66.2	52	2.0	65	< 150℃	≥100,000	
73	73	50-70	76.4	63	2.0	63	< 150℃	≥100,000	
80	80	60-80	83.6	68	2.0	61	< 150℃	≥100,000	
89	89	60-80	92.6	75	2.0	60	< 150℃	≥100,000	
100	100	60-80	105.8	90	2.1	58	< 150℃	≥100,000	
114	114	60-80	117.8	102	2.2	56	< 150℃	≥100,000	
125	125	60-80	129.0	113	2.5	50	< 150℃	≥100,000	
150	150	60-100	164	140	2.6	30	< 100℃	Left	
200	200	100-150	225	---	3.0	20	< 100℃	Left	

Nominal Diameter	Common PTFE Bellow			PTFE Bellow With Braid			PTFE Bellow with Braid and reinforcement		
	DN (mm)	Pressure Mpa	Wire bending radius	Temp. °C	Pressure Mpa	Wire bending radius	Temp. °C	Pressure Mpa	Wire bending radius
15	0.65	≥5.0DN	-100℃ ~+150℃	1.6	≥5.0DN	-10℃	2.0	≥5.0DN	-5℃
20	0.62	≥5.0DN		1.6		~+180℃	2.0		~+180℃
25	0.60	≥5.0DN		1.6		-10℃	2.0		-5℃
32	0.50	≥5.0DN		1.6		~+160℃	2.0		+ 170℃
40	0.50	≥4.5DN		1.6		-5℃	2.0		-5℃
50	0.50	≥4.5DN		1.6		~+150℃	1.5		~+150℃
57	0.40	≥4.0DN		1.6		-0℃	1.2		-0℃
65	0.30	≥4.0DN		1.6		+ 80℃	1.0		+ 80℃
73	0.25	≥3.5DN		1.6					
80	0.23	≥3.5DN		1.6					
89	0.20	≥3.5DN	1.6						
100	0.18	≥3.0DN	1.2						
114	0.12	≥3.0DN	1.2						
125	0.08	≥3.0DN	1.0						
150	0.07	5DN	-0℃	1.0	6DN	-0℃	1.2	6DN	-0℃
200	0.05	5DN	+ 80℃	0.8	6DN	+ 80℃	1.0	6DN	+ 80℃

➤ EXPANSION JOINT PRODUCTION

Universal Expansion Joint (TB Type)



The Product Structure Diagram

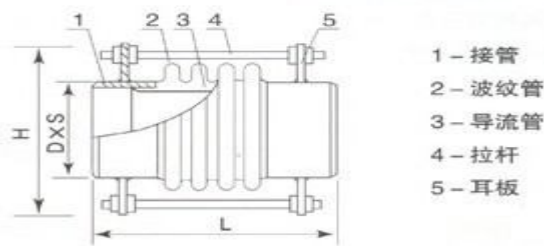

1. Connection Tube 2. Bellows 3. Diversion pipe 4. Rod 5. Ear plate

The Product Structure Features

This type expansion joint is made of one bellows and connection tube in two sides. By flexible deformation of the bellows to absorb the pipeline axial displacement (a small amount of lateral, angular displacement), the end to take over or taken over directly with the pipeline welding, or welding on a flange and pipe flange connection. The small lever on the expansion joint is a rigid support in the transport process or as a product pre-deformation adjustment is not load-bearing parts. Such expansion joint structure is simple, low cost, and thus all possible in the pipeline should be given priority to be taken into account.

Technique Parameter

Nominal Diameter DN mm	Bellows		Compensation Amount		Stiffness		Radial shape Maximum size D mm	Total length L mm	
	Wave No. s n	Effective area A c m ²	Axial X ₀ mm	Lateral Y ₀ mm	Axial K _{X0} mm	Lateral K _{Y0} mm		Connection form	
							Connection Tube	Flange	
									J

Design pressure Pd = 1.6Mpa (16kgf / c m ²) Fatigue life [N] = 1000									
Design temperature t = 20 ° C c m ²									
300	4	1081	16	2.1	2945	29319	495	426	450
	8		32	8.4	1472	3665		570	594
350	4	1276	16	1.9	3229	37297	577	426	450
	8		32	7.7	1614	4741		570	594
400	4	1626	16	1.7	3690	55262	626	426	450
	8		32	6.7	1845	6908		570	594
450	4	2011	16	1.5	4145	76764	678	426	450
	8		32	6.0	2072	9596		570	594
500	4	2437	16	1.4	4600	103250	729	426	450
	8		32	5.4	2300	12906		570	594
600	4	3484	27	3.3	2908	33590	830	576	600
	8		54	1.3	1454	4199		816	840
700	4	4754	31	3.2	2656	41870	980	576	
	6		46	7.1	1771	12406		696	
800	4	6055	30	2.8	2924	58704	1080	576	
	6		46	6.2	1949	17394		96	
900	4	7512	30	2.5	3205	79817	1180	676	
	6		45	5.5	2136	23649		796	
1000	4	3914	32	2.4	4104	126735	1280	676	
	6		48	5.3	2736	37551		796	
1100	4	11103	32	2.1	4773	164662	1380	676	
	6		47	4.8	2982	48789		796	
1200	4	13050	32	2.0	4843	209568	1480	676	
	6		47	4.4	3229	62094		796	

Rotary Compensator

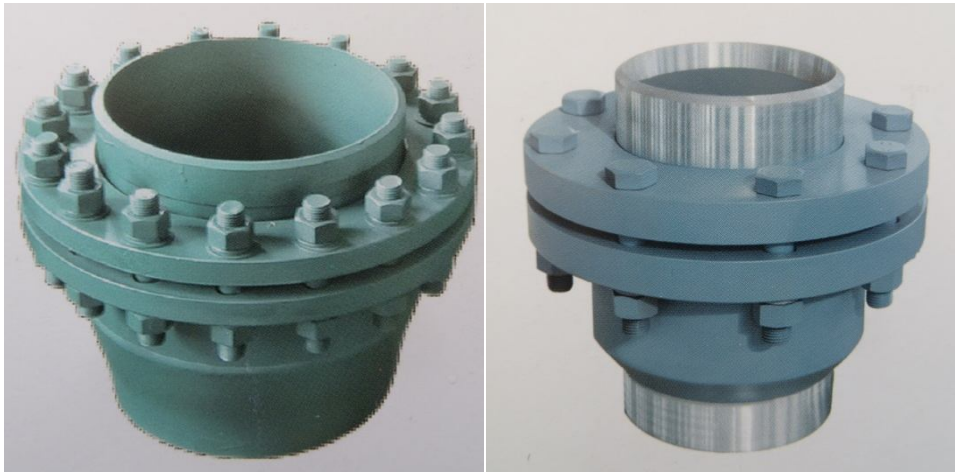

The Product Structure Diagram

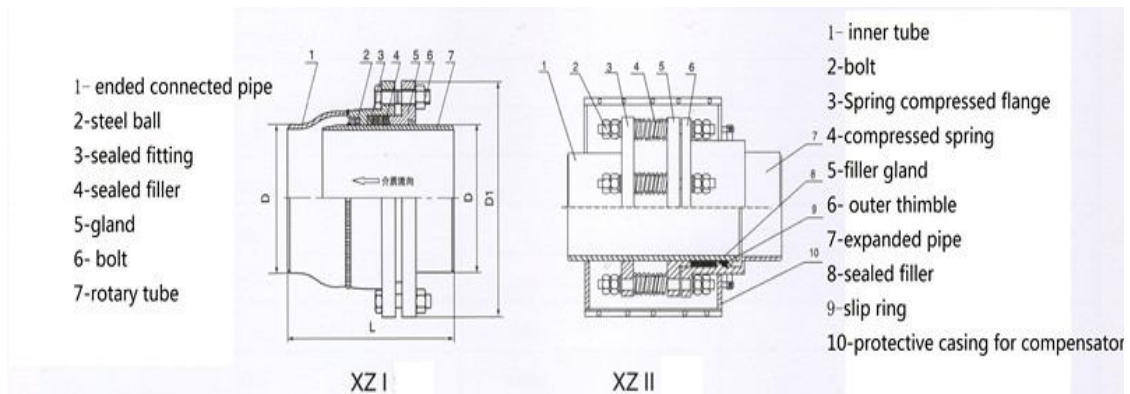

The Product Structure Features

Single product structure is simple, usually combination by two to three rotating compensators (possible combination with two), a short tube coupling arm, four 90 ° elbows and 1~2 small angle elbow to establish a set of compensation structure, although this combination increases the cost, but will also increase the amount of compensation, equivalent to 2~3 times of the axial bellows compensator. The biggest advantages is that it assembled from forged or welded thick pipe through fine processing, higher structural strength, transport high temperature and high pressure steam more secure and reliable

Technique Parameter

Nominal Diameter	Connector Outer Diameter	Compensation Δ	Flange Outer Diameter	Length L	Torque M
DN (mm)	mm	mm	mm	mm	KN · m
80	89	0~1000	240	300	1.28
100	108	0~1000	260	300	1.48
125	133	0~1000	280	320	2.1

150	159	0~1200	300	320	2.7
200	219	0~1200	370	320	4.52
250	273	0~1500	430	360	9.33
300	325	0~1800	480	360	16.65
350	377	0~1800	530	360	21.28
400	426	0~1800	580	360	29.72
450	480	0~2000	630	360	41.4
500	530	0~2000	690	400	51.8
600	630	0~2000	790	400	72.45
700	720	0~2000	930	400	82.15
800	820	0~2000	1030	400	106
900	920	0~2000	1130	400	125.5
1000	1020	0~2000	1240	430	143.7
1100	1120	0~2000	1340	430	165.3
1200	1220	0~2000	1440	430	186.6
1300	1320	0~2000	1540	430	203
1400	1420	0~2000	1640	430	234
1500	1520	0~2000	1760	450	257.6
1800	1920	0~2000	2060	480	344.6
2000	2120	0~2000	2120	480	443.9

☆ 1. Rotational torque is the design pressure of 10 kg, more pressure levels, more increasing of the rotational torque.

☆ 2. High temperature, high pressure rotating compensator ,20% more the length then the low-pressure.

PTFE Expansion Joint



The Product Structure Diagram

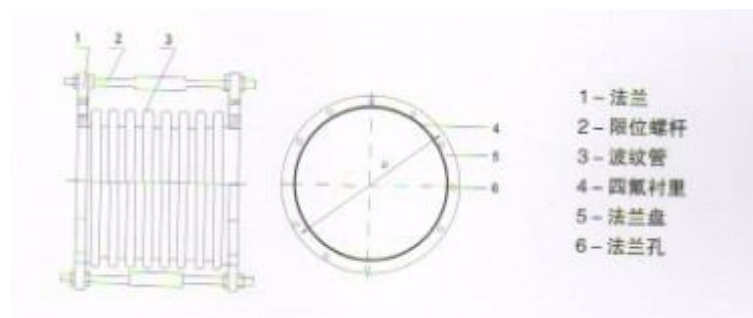

1.Flange 2.Limit screw 3.Bellows 4.PTFE lining 5.Flange 6.Flange holes

The Product Structure Features

This expansion joint is used to eliminate stretching caused by climate change or the thermal expansion, displacement caused by other reasons in the pipe, container and equipment, which as a cushioning device. It can be installed on both ends in the pump of exit and entrance or other high-frequency mechanical, to reduce or eliminate the vibration and improve the life of the pipeline and sealing performance. To solve the problem which the metal compensator can't do, reduce the enterprise costs, improve production efficiency. In addition, it can also be used to absorb the deviation design and the actual installation. Works reliably, compact structure, strong compensate ability, a variety of media corrosion resistant and long life.

Technique Parameter

Spec DN mm	Three waves of the maximum compensate ability				Allow the largest work force			3 waves length L mm	Connection flange size			
	Axial ΔX mm	Transverse ΔY mm		Angular $\Delta \theta$	Internal pressure		Negative pressure Kpa		PN0.6Mpa		PN1.0Mpa	
		02-1	02-2		TF02-1	TF02-2			K	n-M	K	n-M
25	12	8	10	20	0.6	0.7	57	65	75	4-M10	85	4-M12
32	14	12	16	20	0.6	0.7	52	70	90	4-M12	100	4-M16
40	17	14	18	20	0.55	0.6	47	75	100	4-M12	110	4-M16
50	20	17	22	20	0.55	0.6	43	82	110	4-M12	125	4-M16
65	22	20	26	20	0.55	0.6	38	88	130	4-M12	145	4-M16
80	24	24	32	20	0.5	0.6	33	92	150	4-M16	160	8-M16
100	26	25	33	20	0.5	0.6	28	95	170	4-M16	180	8-M16
124	29	25	33	20	0.4	0.5	24	105	200	8-M16	210	8-M16
150	32	20	26	20	0.4	0.5	18	115	225	8-M16	240	8-M20
200	40	20	26	20	0.35	0.4	17	125	280	8-M16	295	8-M20
250	42	20	27	15	0.3	0.35	14	135	335	12-M16	350	12-M20
300	44	20	27	15	0.3	0.35	13	145	395	12-M20	400	12-M20
350	46	20	27	15	0.2	0.25	13	150	445	12-M20	460	
400	46	20	27	15	0.1	0.1	11	160	495	16-M20	515	16-M22
450	48	12	16	15	0.1	0.1	11	180	550	16-M20	565	20-M22
500	48	12	16	15	0.08	0.1	11	200	600	20-M24	620	20-M27
600	49	12	16	15	0.05	0.06	10	220	705	24-M24	725	20-M27

700	50	12	16	15	0.05	0.06	10	240	810	24-M27	----	-----
800	50	10	13	15	0.05	0.06	10	260	920	24-M27	----	-----
900	50	10	13	15	0.03	0.035	9	280	1020	24-M27	----	-----
1000	52	10	13	15	0.03	0.035	9	300	1120	28-M27	----	-----
1200	52	8	10	15	0.03	0.035	7	320	----	-----	----	-----
1400	54	8	10	15	0.02	0.025	7	340	----	-----	----	-----
1600	54	8	10	15	0.01	0.01	7	360	----	-----	----	-----

Large Rod Expansion Joint



The Product Structure Diagram

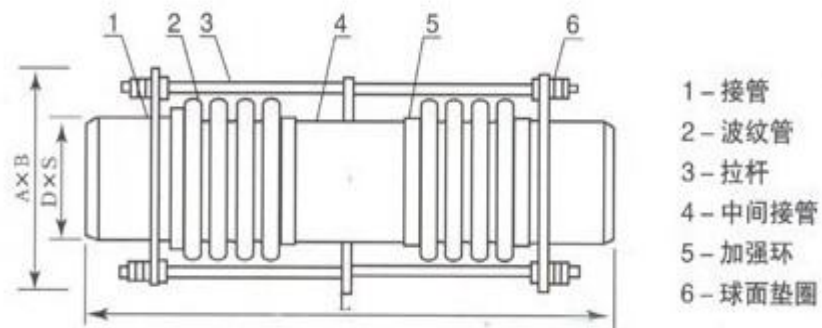

1. Connection tube 2. Bellows 3. Rod 4. Middle connection tube 5. Strengthen ring 6. Spherical washer

The Product Structure Features

The expansion joint is mainly composed of two bellows, middle connection tube and one large rod, it can absorb the lateral displacement in any plane of the pipe system. The spherical nut on the large rod moves around the spherical washers when displacement, and the large rod also has the ability to bear internal pressure thrust.

Technique Parameter

Nominal Diameter DNmm	Wave No. s n	Effective Area Ac m ²	Y-lateral compensation amount (mm) Ky-lateral stiffness (N / mm)										Radial shape maximum Size Dmm
			Total Length L mm										
			1500		2000		2500		3000		3500		
			Y _o	K _{yo}	Y _o	K _{yo}	Y _o	K _{yo}	Y _o	K _{yo}	Y _o	K _{yo}	
Design pressure Pd = 1.6Mpa (16kgf / c m ²) fatigue life[N] = 1000 Designtemperaturet= 20° Cc m ²													
400	8 (4+4)	1626	52	258	86	130	121	55	156	34			700×760
450		2011	46	359	77	144	108	77	139	48			700×750
500		2437	42	482	69	193	97	103	125	64			810×890
600		3484	41	709	80	236	120	116	160	69	201	45	900×980
700		4754	40	884	77	295	116	145	155	86	194	57	970
800		6055	35	1240	68	413	101	203	135	120	169	79	1070
900		7512	31	1685	60	562	90	276	120	164	150	108	1170
1000		9315	30	2676	57	892	86	439	115	260	144	172	1300
Design pressure Pd = 2.5Mpa (25kgf / c m ²) fatigue life[N] = 1000 Designtemperaturet= 20° Cc m ²													
200	8 (4+4)	535	94	58	147	25	201	14					500×560
250		779	76	102	118	45	161	25	204	16			540×600
300		1075	76	130	121	56	166	31	211	20			570×630
350		1269	62	209	103	84	144	45	186	28			670×730
400		1626	53	304	89	122	125	65	161	40			700×760
450		2011	47	421	78	169	109	90	141	56			770×750
500		2428	43	566	71	227	99	121	128	75			810×890
600		3477	35	1243	68	414	102	204	136	121	171	180	900×980

Rubber Expansion Joint

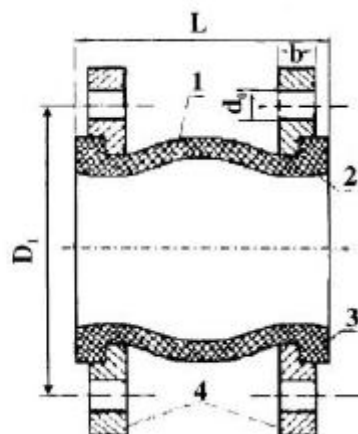

1. Outer/Inner rubber: NR/NBR/EPDM 2. Key frame: Nylon Cord Fabric 3. Pressurized ring: Steel wire strand 4. Flange: Carbon Steel

The Product Structure Features

Rubber Expansion Joint is also called flexible rubber joint is a shock absorber, pipe shock absorber, shock proof box and soft joint etc. It is a pipe joint of high-Flexibility, high-gas tightness, resistance to medium and climate. It's used widely in key projects of chemical industry, construction, water supply, drainage, petroleum light and heavy industry, refrigeration, health, water heating, fireproof and power etc.

Technique Parameter

Nominal Diameter DN		Length mm	Axial displacement		Horizontal displacement mm	Delexion angle ($\alpha 1 + \alpha 2$)
mm	in		Extension mm	Compression mm		
32	1 1/4	95	6	9	9	15'
40	1 1/2	95	6	10	9	15'
50	2	105	7	10	10	15'
65	2 1/2	115	7	13	11	15'
80	3	135	8	15	12	15'
100	4	150	10	19	13	15'
125	5	165	12	19	13	15'
150	6	180	12	20	14	15'
200	8	210	16	25	22	15'
250	10	230	16	25	22	15'
300	12	245	16	25	22	15'
350	14	255	16	25	22	15'
400	16	255	16	25	22	15'
450	18	255	16	25	22	15'
500	20	255	16	25	22	15'
600	24	260	16	25	22	15'

700	28	260	16	25	22	15'
800	32	260	16	25	22	15'
900	36	260	16	25	22	15'
1000	40	260	18	26	24	15'
1200	48	260	18	26	24	15'

☆ 1. DN32-1200PN-1Mpa 2. DN32-300PN-16Mpa 3. DN32-300PN-25Mpa 4. For special order please write and provide drawing sample. 5. This product is available for high-floor water supply. The pipe must be equipped with fixed support or fixed bracket, if not, the product shall be installed with escapement, the force of fixed support or bracket must be greater than axial force. If not the escapement shall also be installed.

➤ **Product Show**
Flexible Metal Hose



Connection tube ends metal hose

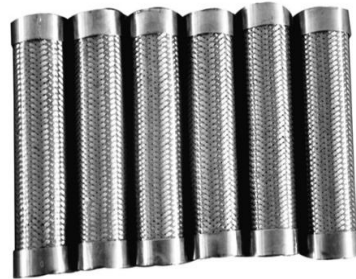

Braided corrugated hose



Refrigeration equipment hose



Flange ends flexible metal hose



Quick joint ends flexible metal hose



Steel net braided hose



Fire sprinkler hose



Different end metal hose



EGR pipe



Vacuum Bellow

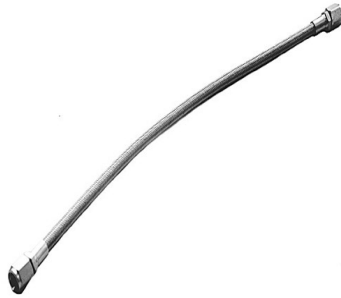

Gas metal hose



Exhaust pipe

Expansion Joint



Flange ends



Connection tube ends



Ball type expansion joint



Thick Wall compensator



Rectangular/Round compensator



Fabric expansion joint



Unrestraint compensator



Spherical sleeve compensator



Axial sleeve compensator



Direct buried compensator



Rubber expansion joint



Flexible rubber joint

科技改变未来

TECHNOLOGICAL CHANGE IN THE FUTURE



江苏大明波纹管有限公司

JIANGSU DAMING CORRUGATED PIPE CO.,LTD.



地 址(Address): 姜堰经济开发区陈庄路12号
No.12,Chenzhuang Road,Economic Development Zone,Jiangyan City

服务热线(Service Hotline):0086-523-88089828

电 话(Tel): 86-18082337926

传 真(Fax): 0523-88808266 88122269

网 址(Website): www.dmbwg.com

www.jsdmbwg.com

邮 箱(E-mail): luckylin@dmbwg.com

qfexport@hotmail.com